



## Portamate PBR-001 Wood Rack

The Portamate Wood Rack is compact storage system designed to help you organize your workshop. It can be used for a variety of materials including timber, moldings, pipes, PVC and more. Applications include garage walls, basements, sheds, and even outdoor fences.

- The Wood Rack provides 6 levels with a capacity of **110 lb. (50 kg.) per level**. It is easy to install and easy to customize. See instructions and illustrations on back of box.
- Due to product improvements, actual product may vary slightly. Made in China. 1 year warranty.

### CONTENTS:

A: Screws (12) B: Vertical Bars(2) C: Horizontal Bars (12) D: Spacers (6)

**WARNING: Ensure your mounting location is capable of withstanding the additional load. Never overload your rack. Follow the assembly and mounting instructions on back of box.**

### Assembly Instructions:

1. **Note:** Vertical bars can be used as templates to mark your drilling locations before assembly.

**Step 1:** Locate the bottom of the long vertical bar. It has a small screw hole  $\frac{1}{2}$  inch (13mm.) from the end. Insert a screw **(A)**. Locate the bottom of an orange horizontal bar. It has a small notch **(B)** as shown in the inset photo. Slide the orange bar down the length of the vertical bar from the top until it rests in position against the screw.

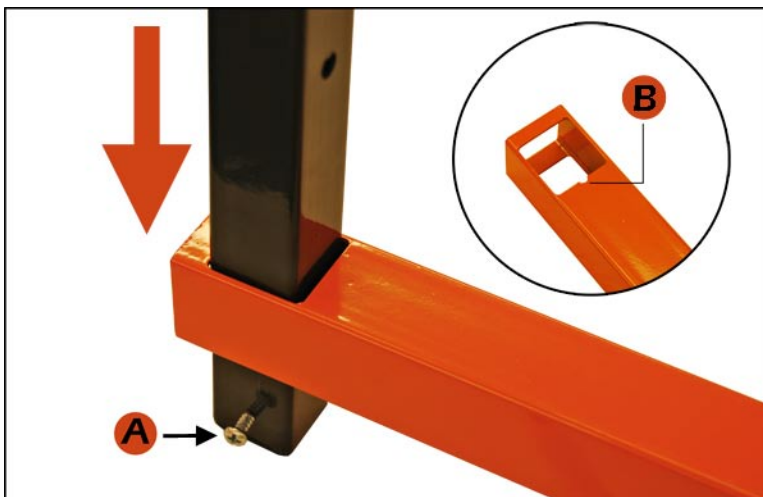

- Step 2:** Insert a screw into the next hole up, then slide another orange bar into position. Continue this process until all the bars are fitted, being careful that all the notches face down. Repeat this process for the other side.



**Note:** Alternative rack positions can be achieved by drilling additional holes where desired using a 3/32" (2.5mm) drill bit.

- Step 3:** Installing to drywall or other paneled wall sheeting: Locate a solid structural support for your Portamate Wood Rack is very important. Ensure that you are securely contacting the center of the wall studs. Distance between the vertical bars is optional. The recommended distance to support the designed weight capacity is **4 – 6 ft. (120 – 180 cm.)** For longer material or greater weight, multiple wood racks can be used.

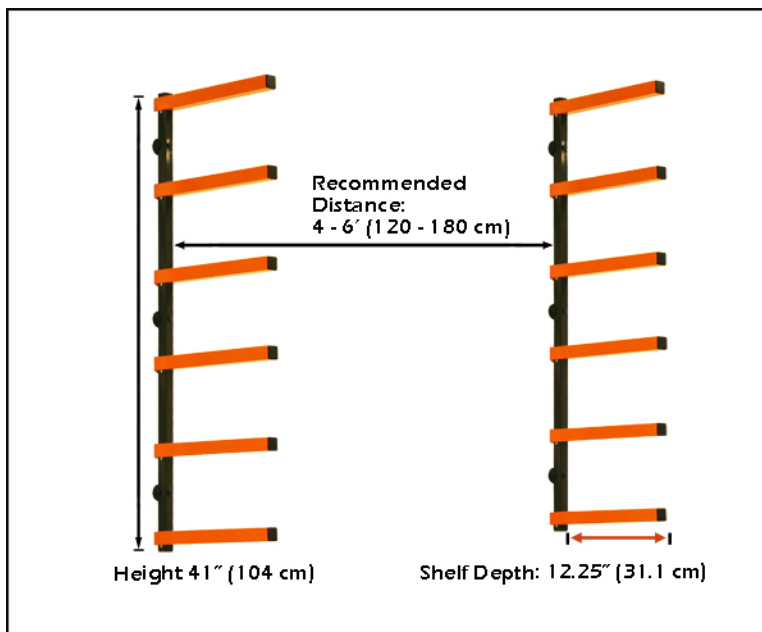

4. **Step 4:** Position the Spacers (C) behind the mounting holes, and fasten to the wall using the fasteners (not included) described in the recommended installations.



**Note:** Customizing your Portamate Wood Rack is easy and practical to solve your workshop storage needs.

#### **Recommended Installations:**

1. See Step 3 for **drywall** or other paneled wall sheeting.
2. **Installing on masonry walls:** Use  $\frac{1}{4}$ " (6mm) masonry anchors. The assembled wood rack is  $1\frac{5}{8}$ " (41 mm.) thick so a suitable length of anchor is  $2\frac{3}{4}$ " (71 mm.) minimum. Use the proper drill bits and fasteners to create a solid, strong hold of your wood rack.
3. **Installing on a steel wall or shed:** Mount the racks securely to a portion of the structural framework at top and bottom or sides so the weight is properly transferred to the wall. To do this, first install floor to roof verticals such as a 2 x 4 and secure with fasteners every 12" (300 mm.). The assembled wood rack is  $1\frac{5}{8}$ " (41 mm.) thick so a suitable length of fastener is  $2\frac{3}{4}$ " (71 mm.) and  $\frac{1}{4}$ " (6 mm.) diameter.



4. **Installing on wood fence:** Structural reinforcement of the fence section is required because it was not designed to carry a load. This can easily be achieved by installing the proper horizontal supports between fence posts and then using vertical supports as shown. The assembled wood rack is 1 5/8" (41 mm.) thick so a suitable length of fastener is 2 3/4" (71 mm.) and 1/4" (6 mm.) diameter.

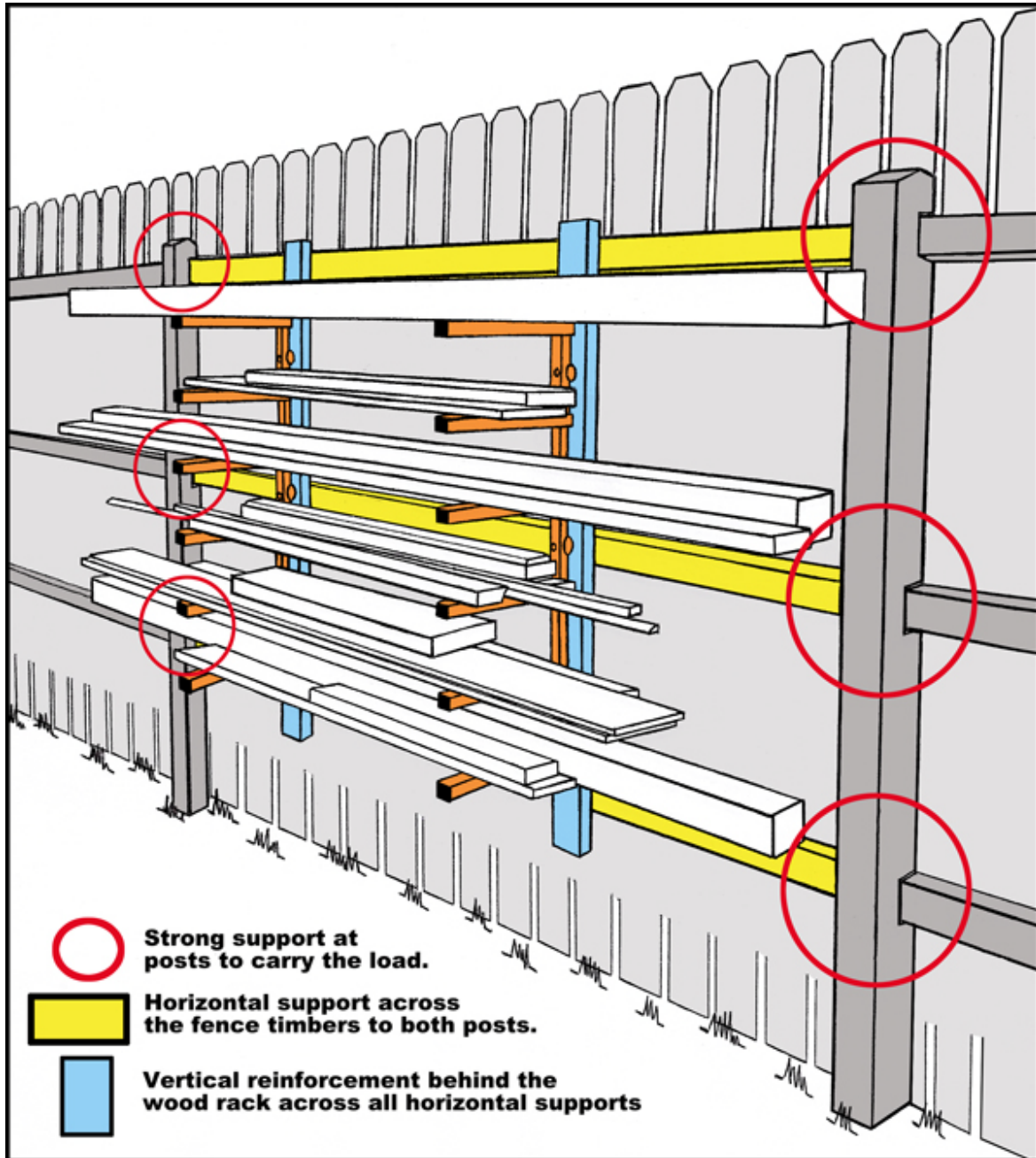

### Customizing Your Wood Rack:

1. For Outdoor Use: Weather protection of your materials is achieved by creating a custom cover. Anchor a horizontal board the length of your material above the wood rack. Take sheet of vinyl or thick plastic and attach several thin wood battens to the inside with staples to keep it from flapping around. The batten at the top is used to screw it to the anchor board. Reinforcing strips can be glued in to avoid puncture from the horizontal rack bars.
2. Convenient Shelf: The bottom rack is easily converted to a shelf to store shorter pieces of material. A lip can be added to your shelves to prevent roll-off or round stock material.
3. Handy Hooks: If you mount your wood rack closer to the ceiling, the bottom rack can be customized to provide great locations for hooks to organize power cords or power tools.

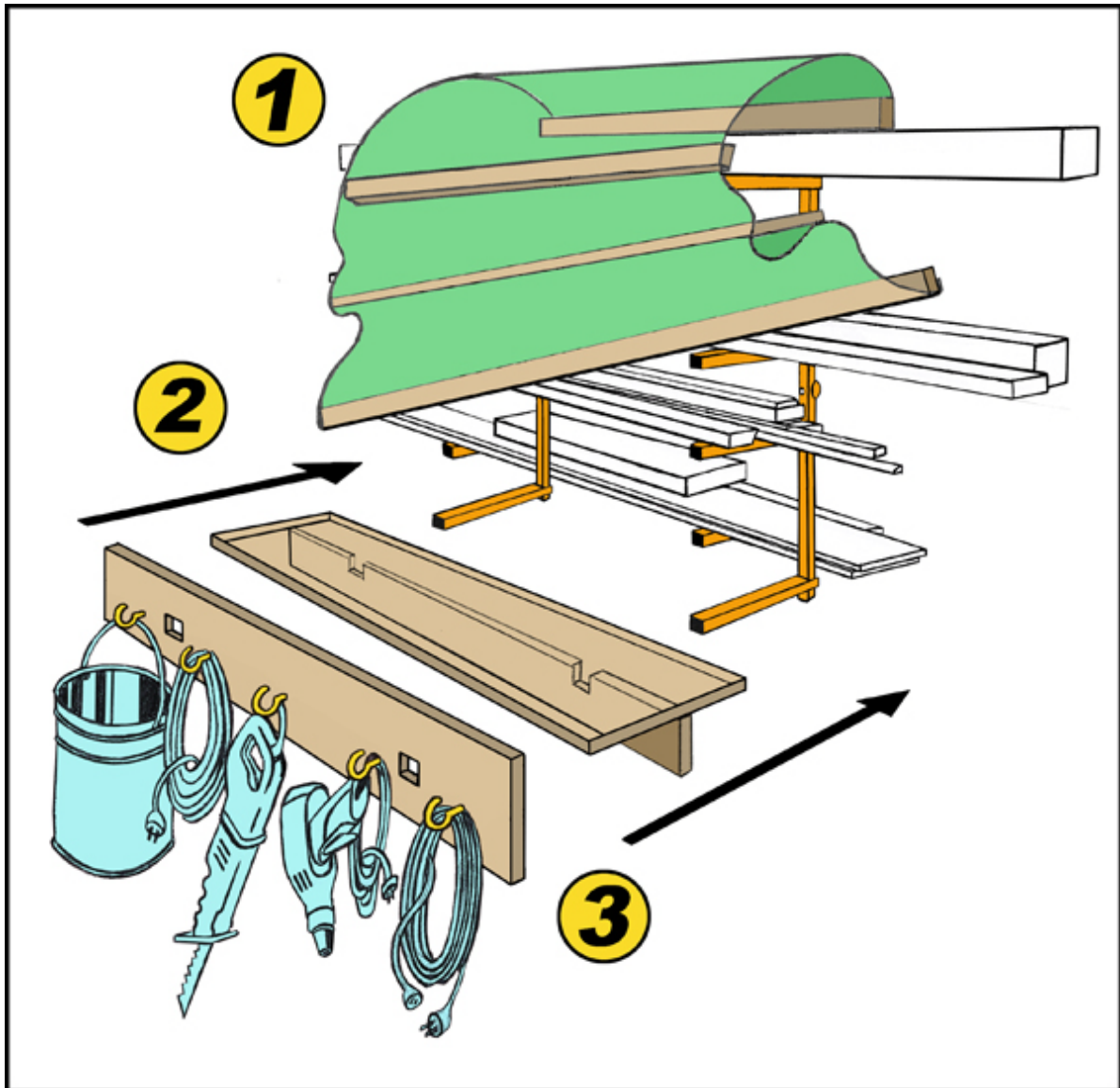

Copyright 2010, HTC Products, Inc.

6520 Bethuy Rd. Fair Haven, MI 48023

For Customer Service Phone: 1-800-624-2027